

Features

■ Non lubrication

Special housing and bushing enable self lubrication of piston rod.

■ High quality long service life

Hard anodised aluminium cylinder tubes offer high resistance to corrosion and low internal friction.

■ Automatic air cushioning

Pneumatic cushioning at both ends without adjusting.

■ Low noise level

Add cushion pad to reduce impact sound and vibration.

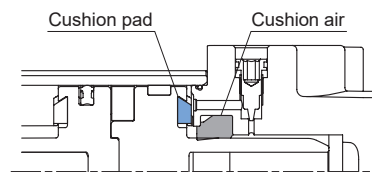

■ ISO 15552 standard specification

Conforms to ISO 15552 specification enabling worldwide interchangeability.

■ Cylinder mountings

Available with comprehensive internationally recognised range of fixed and flexible mountings.

Table for standard stroke

Tube I.D.	Stroke (mm)	Max. stroke(mm)
ø32,40	50,75,100,125,150,175,	1800
ø50,63	200,250,300,350,400,	2000
ø80,100	450,500,600,700,800	2500

* Please contact us if the stroke is out of specification.

Specification



Model	MCQV3		
Tube I.D. (mm)	32,40	50,63	80,100
Medium	Air		
Operating pressure range	0.05~1 MPa		
Proof pressure	1.5 MPa		
Ambient temperature	-5~+60°C (No freezing)		
Available speed range	50~500 mm/sec		
Sensor switch	RCA (Please refer to page 8-8)		
Sensor switch holder	HV1	HV2	HV3

Order example

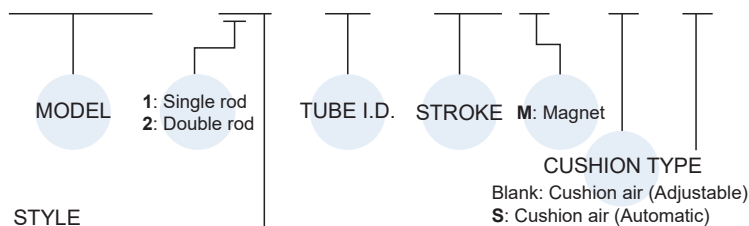
MCQV3 — 11 — 63 — 100 M — S — T



STYLE

Code	Symbol	Description
1 1		Double acting / Male thread
2 1		Double rod / Male thread
2 7		Double rod / Adjustable male thread Please mark "adjustable stroke" at order list





* Order example for special specification, refer to page 0-7.





* Rc or NPT thread are also available, please contact us.







T: With magnet, TA/TB is assembled

* Tube, piston rod and tie rod are extended, and an extra piston is added.



Accessories & Connector

Accessories							
Code	LB (Purchase 2 pcs)	CA	CA2	CB	CB2	CDB (Purchase CB+PIN)	CDB2 (Purchase CB+PIN)
Mounting Tube I.D.							
ø32	LB-Q2-32	CA-Q2-32	CA2-Q2-32	CB-Q2-32	CB2-Q2-32	CDB-Q2-32	CDB2-Q2-32
ø40	LB-Q2-40	CA-Q2-40	CA2-Q2-40	CB-Q2-40	CB2-Q2-40	CDB-Q2-40	CDB2-Q2-40
ø50	LB-Q2-50	CA-Q2-50	CA2-Q2-50	CB-Q2-50	CB2-Q2-50	CDB-Q2-50	CDB2-Q2-50
ø63	LB-Q2-63	CA-Q2-63	CA2-Q2-63	CB-Q2-63	CB2-Q2-63	CDB-Q2-63	CDB2-Q2-63
ø80	LB-Q2-80	CA-Q2-80	CA2-Q2-80	CB-Q2-80	CB2-Q2-80	CDB-Q2-80	CDB2-Q2-80
ø100	LB-Q2-100	CA-Q2-100	CA2-Q2-100	CB-Q2-100	CB2-Q2-100	CDB-Q2-100	CDB2-Q2-100

Accessories				Rod nut	
Code	FAC	FBC	FAC2	FBC2	NUT
Mounting Tube I.D.					
ø32	FAC-Q2-32		FAC2-Q2-32		NUT-M10x1.25x5Hx17B
ø40	FAC-Q2-40		FAC2-Q2-40		NUT-M12x1.25x6Hx19B
ø50	FAC-Q2-50		FAC2-Q2-50		NUT-M16x1.5x8Hx24B
ø63	FAC-Q2-63		FAC2-Q2-63		
ø80	FAC-Q2-80		FAC2-Q2-80		NUT-M20x1.5x10Hx30B
ø100	FAC-Q2-100		FAC2-Q2-100		

Accessories				Connector			
Code	TA	TB	TC	SDS	Y	I	YS (Y+Floating pin)
				Mid section support (Stroke over 1000mm)			
Mounting Tube I.D.							
ø32	TC-Q2-32			SDS-Q2-32	Y-Q2-32	I-Q2-32	YS-Q2-32
ø40	TC-Q2-40			SDS-Q2-40	Y-Q2-40	I-Q2-40	YS-Q2-40
ø50	TC-Q2-50			SDS-Q2-50	Y-Q2-50	I-Q2-50	YS-Q2-50
ø63	TC-Q2-63			SDS-Q2-63			
ø80	TC-Q2-80			SDS-Q2-80	Y-Q2-80	I-Q2-80	YS-Q2-80
ø100	TC-Q2-100			SDS-Q2-100			

Pin

Applicable	YS connector	Y&I connector	CA&CB accessories
Code	PIN-S	PIN-Y-P (with split pin)	PIN-CB-P (with split pin)
Fig Tube I.D.			
ø32	PIN-Q2-32-S	PIN-Q2-32-2-P	PIN-Q2-32-1-P
ø40	PIN-Q2-40-S	PIN-Q2-40-2-P	PIN-Q2-40-1-P
ø50	PIN-Q2-50-S	PIN-Q2-50-2-P	PIN-Q2-50-1-P
ø63			PIN-Q2-63-1-P
ø80	PIN-Q2-80-S	PIN-Q2-80-2-P	PIN-Q2-80-1-P
ø100			PIN-Q2-100-1-P

Order example of self-assembled

The tube I.D. ø40 of LB accessories, Y connector and pin.

No.	Order number	Qty
1	LB-Q2-40	2
2	Y-Q2-40	1
3	PIN-Q2-40-2-P	1

* To order accessories/ connectors/ pin separately, please place orders separately according to the order codes in the above table.

Order example of factory assembled

△ Cylinders and accessories are distinguished by the symbol " + ".

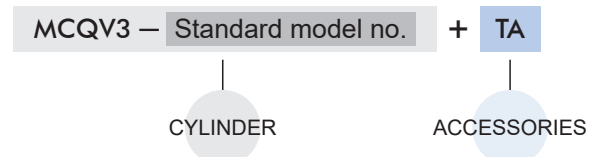

MCQV3-11 Inside structure & Parts list

ISO 15552 STANDARD CYLINDER



Single rod 11 type

Cushion air (Adjustable)

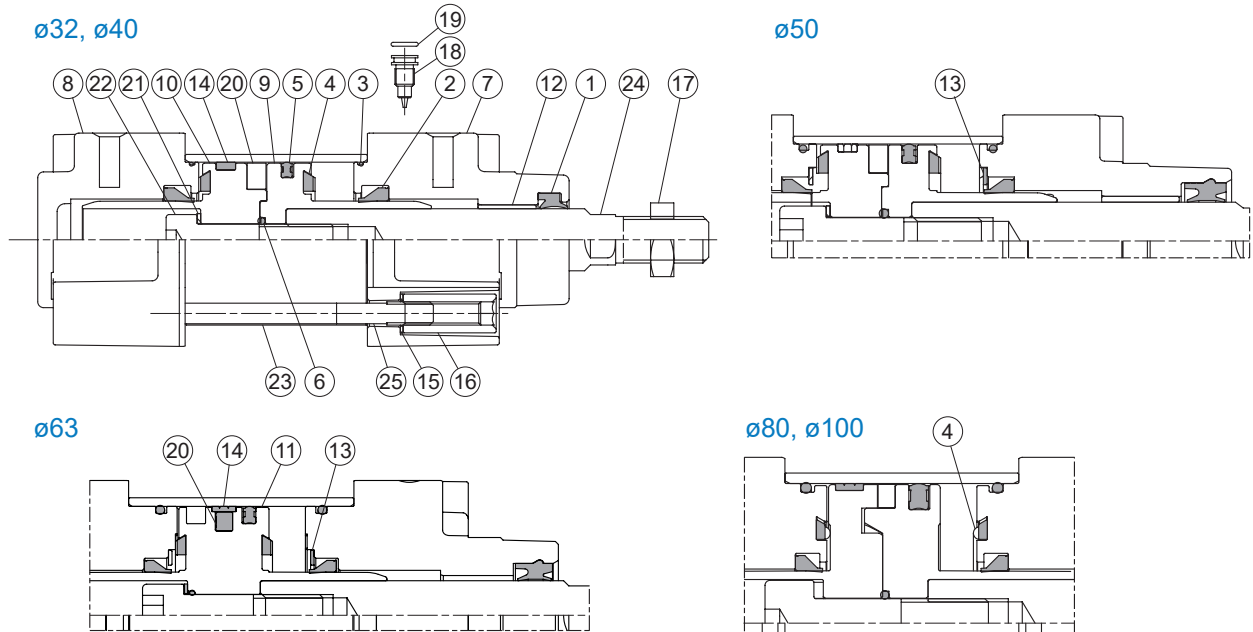

No.	Part name	Material	Q'y	Component parts (inclusion)	Repair kits (inclusion)	Note
1	Rod packing	NBR / TPU	1	●	●	ø50, 63: TPU
2	Cushion packing	NBR	2	●	●	
3	O-ring	NBR	2	●	●	
4	Cushion pad	NBR	2	●	●	
5	Piston packing	NBR	1	●	●	
6	O-ring	NBR	1	●	●	
7	Rod cover	Aluminum alloy	1	●		
8	Head cover	Aluminum alloy	1	●		
9	Piston #1	Aluminum alloy	1	●		
10	Piston #2	Aluminum alloy	1	●		
11	Piston	Aluminum alloy	1	●		Only for ø63
12	Bush	Bearing alloy	1	●		
13	Washer	Carbon steel	2	●		Only for ø50, ø63
14	Wear ring	Resin	1	●		
15	Washer	Aluminum alloy	8	●		
16	Tie rod nut	Carbon steel	8	●		
17	Piston rod nut	Carbon steel	1	●		
18	Needle valve	Copper alloy	2	●		
19	O-ring	NBR	2	●		
20	Magnet ring	Magnet material	1	◎		◎ Option
21	Washer	Aluminum alloy	1	●		
22	Hex bolt	Carbon steel	1	●		
23	Cylinder tube	Aluminum alloy	1			
24	Piston rod *1	Carbon steel	1			
25	Tie rod	Carbon steel	4			

*1. When customized material is bearing steel, only two-side across flat (wrench flat) is available.

MCQV3-11-S Inside structure & Parts list

ISO 15552 **STANDARD CYLINDER**



Single rod 11 type

Cushion air (Automatic)

ø32, ø40

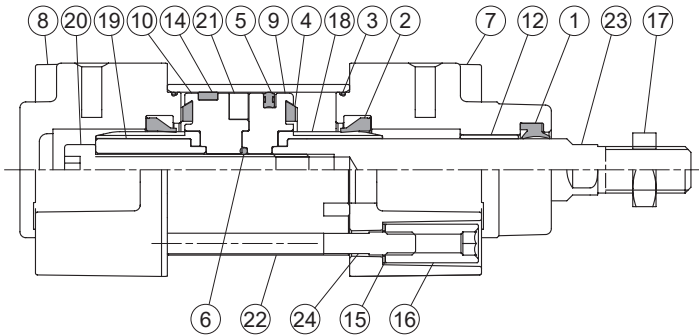

ø50

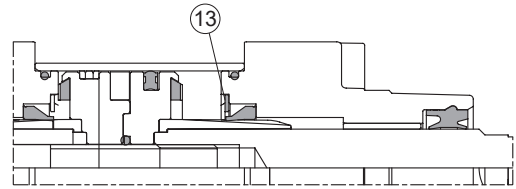

ø63

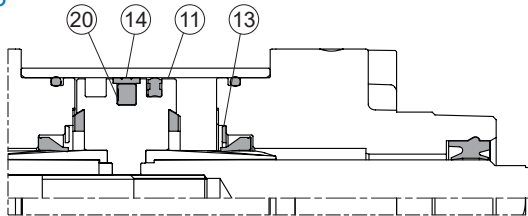

ø80, ø100

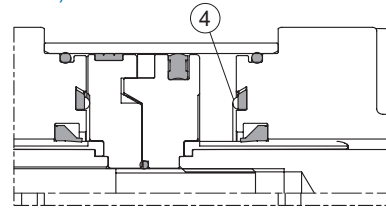

No.	Part name	Material	Q'y	Component parts (inclusion)	Repair kits (inclusion)	Note
1	Rod packing	NBR / TPU	1	●	●	ø50, 63: TPU
2	Cushion packing	NBR	2	●	●	
3	O-ring	NBR	2	●	●	
4	Cushion pad	NBR	2	●	●	
5	Piston packing	NBR	1	●	●	
6	O-ring	NBR	1	●	●	
7	Rod cover	Aluminum alloy	1	●		
8	Head cover	Aluminum alloy	1	●		
9	Piston #1	Aluminum alloy	1	●		
10	Piston #2	Aluminum alloy	1	●		
11	Piston	Aluminum alloy	1	●		Only for ø63
12	Bush	Bearing alloy	1	●		
13	Washer	Carbon steel	2	●		Only for ø50, ø63
14	Wear ring	Resin	1	●		
15	Washer	Aluminum alloy	8	●		
16	Tie rod nut	Carbon steel	8	●		
17	Piston rod nut	Carbon steel	1	●		
18	Shock absorber axis	Resin	2	●		
19	Piston nut	Aluminum alloy	1	●		
20	Hex bolt	Carbon steel	1	●		
21	Magnet ring	Magnet material	1	◎		◎ Option
22	Cylinder tube	Aluminum alloy	1			
23	Piston rod *1	Carbon steel	1			
24	Tie rod	Carbon steel	4			

*1. When customized material is bearing steel, only two-side across flat (wrench flat) is available.

MCQV3-21/27 Inside structure & Parts list

ISO 15552 STANDARD CYLINDER



Double rod 21 / 27 type

Cushion air (Adjustable)

ø32, ø40

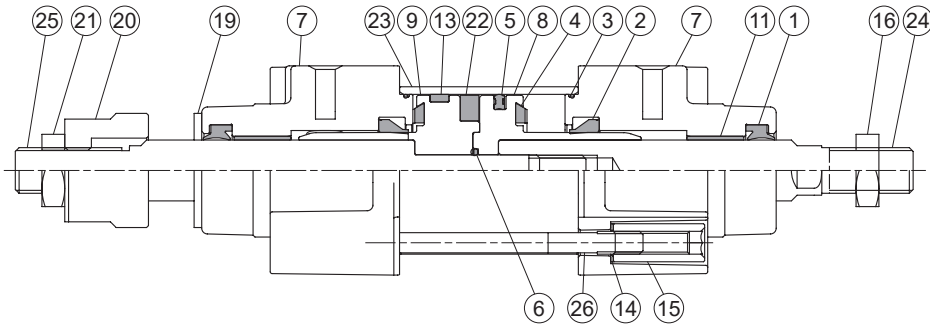

ø50

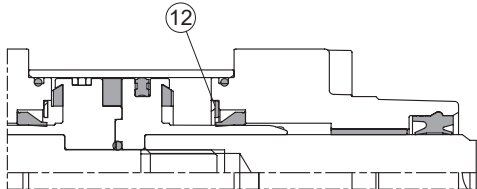

ø63

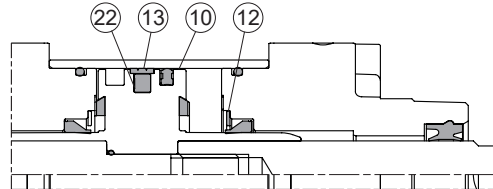

ø80, ø100

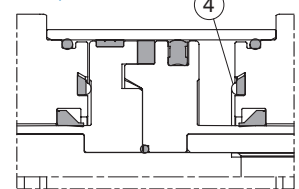

No.	Part name	Material	Q'y	Component parts (inclusion)		Repair kits (inclusion)	Note
				21 type	27 type		
1	Rod packing	NBR / TPU	2	●	●	●	ø50, 63: TPU
2	Cushion packing	NBR	2	●	●	●	
3	O-ring	NBR	2	●	●	●	
4	Cushion pad	NBR	2	●	●	●	
5	Piston packing	NBR	1	●	●	●	
6	O-ring	NBR	1	●	●	●	
7	Rod cover	Aluminum alloy	2	●	●		
8	Piston #1	Aluminum alloy	1	●	●		
9	Piston #2	Aluminum alloy	1	●	●		
10	Piston	Aluminum alloy	1	●	●		Only for ø63
11	Bush	Bearing alloy	2	●	●		
12	Washer	Carbon steel	2	●	●		Only for ø50, ø63
13	Wear ring	Resin	1	●	●		
14	Washer	Carbon steel	8	●	●		
15	Tie rod nut	Carbon steel	8	●	●		
16	Piston rod nut	Carbon steel	1	●	●		
17	Needle valve	Copper alloy	2	●	●		
18	O-ring	NBR	2	●	●		
19	Gasket	PU	1		●		
20	Adjustable nut	Carbon steel	1		●		
21	Hex nut	Carbon steel	1		●		
22	Magnet ring	Magnet material	1	◎	◎		◎ Option
23	Cylinder tube	Aluminum alloy	1				
24	Piston rod #1 *1	Carbon steel	1				
25	Piston rod #2 *1	Carbon steel	1				
26	Tie rod	Carbon steel	4				

*1. When customized material is bearing steel, only two-side across flat (wrench flat) is available.

MCQV3-21/27-S Inside structure & Parts list

ISO 15552 **STANDARD CYLINDER**



Double rod 21 / 27 type

Cushion air (Automatic)

ø32, ø40

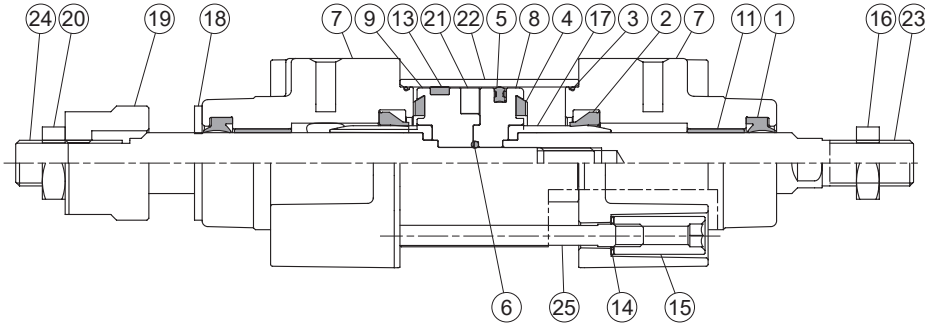

ø50

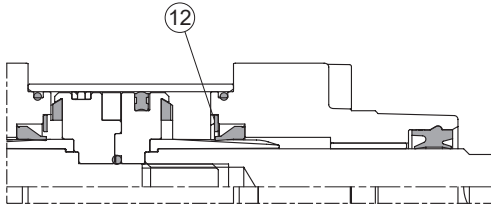

ø63

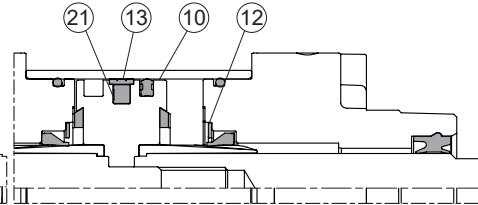

ø80, ø100

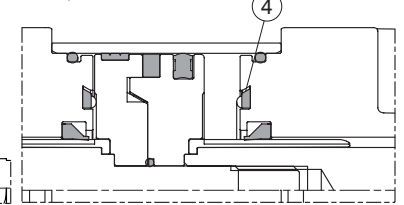

No.	Part name	Material	Q'y	Component parts (inclusion)		Repair kits (inclusion)	Note
				21 type	27 type		
1	Rod packing	NBR / TPU	2	●	●	●	ø50, 63: TPU
2	Cushion packing	NBR	2	●	●	●	
3	O-ring	NBR	2	●	●	●	
4	Cushion pad	NBR	2	●	●	●	
5	Piston packing	NBR	1	●	●	●	
6	O-ring	NBR	1	●	●	●	
7	Rod cover	Aluminum alloy	2	●	●		
8	Piston #1	Aluminum alloy	1	●	●		
9	Piston #2	Aluminum alloy	1	●	●		
10	Piston	Aluminum alloy	1	●	●		Only for ø63
11	Bush	Bearing alloy	2	●	●		
12	Washer	Carbon steel	2	●	●		Only for ø50, ø63
13	Wear ring	Resin	1	●	●		
14	Washer	Carbon steel	8	●	●		
15	Tie rod nut	Carbon steel	8	●	●		
16	Piston rod nut	Carbon steel	1	●	●		
17	Shock absorber axis	Resin	2	●	●		
18	Gasket	PU	1		●		
19	Adjustable nut	Carbon steel	1		●		
20	Hex nut	Carbon steel	1		●		
21	Magnet ring	Magnet material	1	◎	◎		◎ Option
22	Cylinder tube	Aluminum alloy	1				
23	Piston rod #1 *1	Carbon steel	1				
24	Piston rod #2 *1	Carbon steel	1				
25	Tie rod	Carbon steel	4				

*1. When customized material is bearing steel, only two-side across flat (wrench flat) is available.

Order example of component parts

CP – MCQV3 – 2 – 63 M S

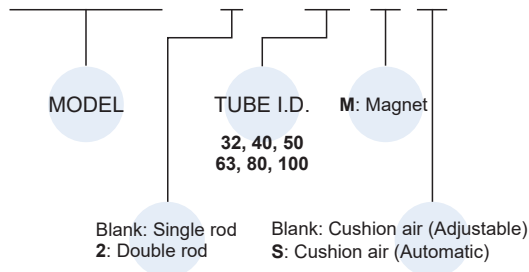

Order example of repair kits

PS – MCQV3 – 2 – 63 S – XB6

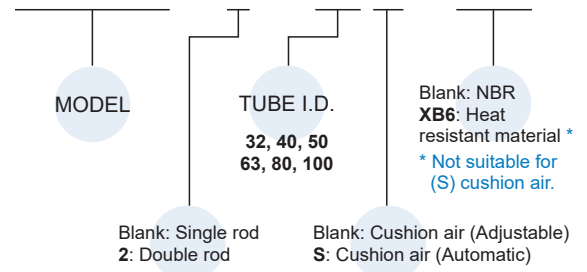

* Order example for Rc or NPT thread please contact us.

Cylinder & accessories weight

Cylinder weight

Unit: kg

Model	Basic weight MCQV3-11	Basic weight (magnet) MCQV3-11	Basic weight MCQV3-11-S	Basic weight (magnet) MCQV3-11-S	Stroke 25 mm MCQV3-11-(S)
Tube I.D.					
ø32	0.510	0.516	0.45	0.456	0.05
ø40	0.717	0.729	0.697	0.709	0.068
ø50	1.114	1.131	1.101	1.118	0.108
ø63	1.689	1.709	1.673	1.693	0.125
ø80	2.464	2.491	2.445	2.472	0.187
ø100	3.682	3.717	3.613	3.648	0.210

Accessories weight

Unit: kg

Model	LB	CA	CA2	CB	CB2	CDB	CDB2	FAC/ FBC	FAC2/ FBC2	TA/TB/TC	SDS
Tube I.D.											
ø32	0.163	0.213	0.07	0.185	0.07	0.170	0.06	0.235	0.07	0.208	0.157
ø40	0.211	0.253	0.09	0.211	0.10	0.230	0.08	0.265	0.09	0.282	0.179
ø50	0.315	0.390	0.16	0.352	0.15	0.410	0.12	0.460	0.17	0.377	0.289
ø63	0.395	0.670	0.23	0.544	0.23	0.550	0.18	0.684	0.20	0.675	0.474
ø80	0.816	1.076	0.40	0.982	0.45	0.870	0.28	1.508	0.40	1.025	0.846
ø100	1.014	1.587	0.50	1.493	0.60	1.400	0.45	1.975	0.56	1.680	1.373

Model	Y	I	Pin		YS
			Y / I	CA / CB	
Tube I.D.					
ø32	0.067	0.082	0.016	0.036	0.018
ø40	0.115	0.141	0.029	0.057	0.031
ø50	0.272	0.334	0.067	0.063	0.070
ø63	0.272	0.334	0.067	0.128	0.070
ø80	0.551	0.553	0.142	0.158	0.150
ø100	0.551	0.553	0.142	0.292	0.150

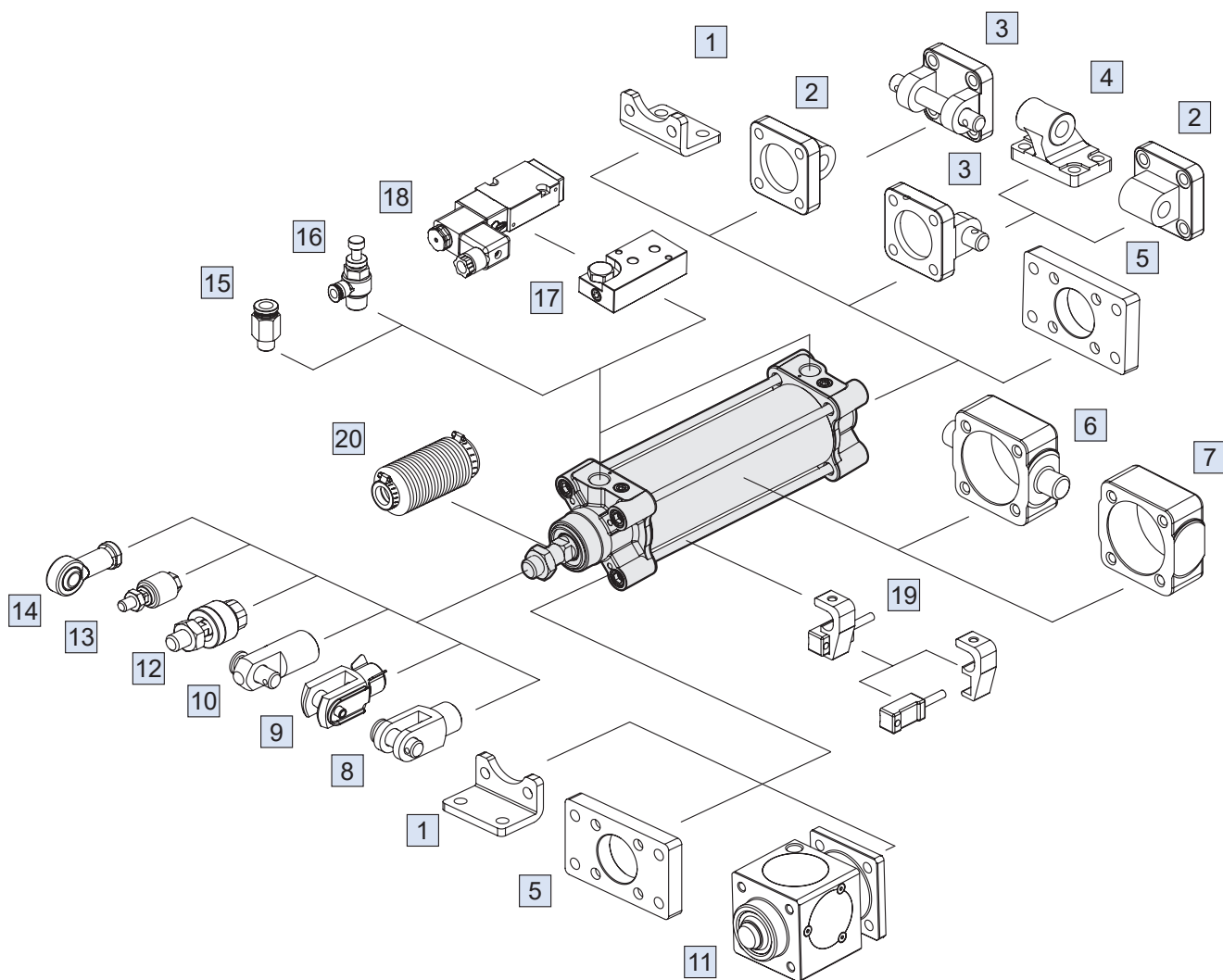

No.	Accessories	Material	Page
1	Mounting accessories LB	Carbon steel	1-51
2	Mounting accessories CA	Cast iron	1-54
	Mounting accessories CA2	Aluminum alloy	1-55
3	Mounting accessories CB+PIN	Cast iron / *1	1-54, 57
	Mounting accessories CB2+PIN	Aluminum alloy	1-55, 57
4	Mounting accessories CDB	Cast iron	1-54
	Mounting accessories CDB2	Aluminum alloy	1-55
5	Mounting accessories FAC/FBC	Carbon steel	1-52
	Mounting accessories FAC2/FBC2	Aluminum alloy	1-53
6	Mounting accessories TA/TB/TC	Cast iron	1-56
7	Mounting accessories SDS	Cast iron	1-56
8	Accessories Y+PIN	Cast iron / *1	1-57

No.	Accessories	Material	Page
9	Accessories YS (Y+Floating pin)	Carbon steel	1-57
10	Accessories I+PIN	Carbon steel	1-57
11	Locking unit MCBQV3	Aluminum alloy+*2	1-92
12	Floating joint MFC	Carbon steel	8-2
13	Floating joint MFCS	Carbon steel	8-5
14	Female rod ends PHS	Carbon steel	8-6
15	Fitting PC (PISCO)	—	8-3 (Vol.1)
16	Speed controller JSC (PISCO)	—	8-15 (Vol.1)
17	Cylinder link seats MVSN-300-C*3	Aluminum alloy	1-69 (Vol.1)
18	Solenoid valve MVSN-220 / 300*3	—	1-65, 67 (Vol.1)
19	Sensor switch RCA+HV*	—	8-8
20	Protective bellows kit	NBR	—

*1. PIN material is carbon steel. *2. Bronze alloy.
*3. Only for tube I.D. $\varnothing 40$, $\varnothing 50$.

11

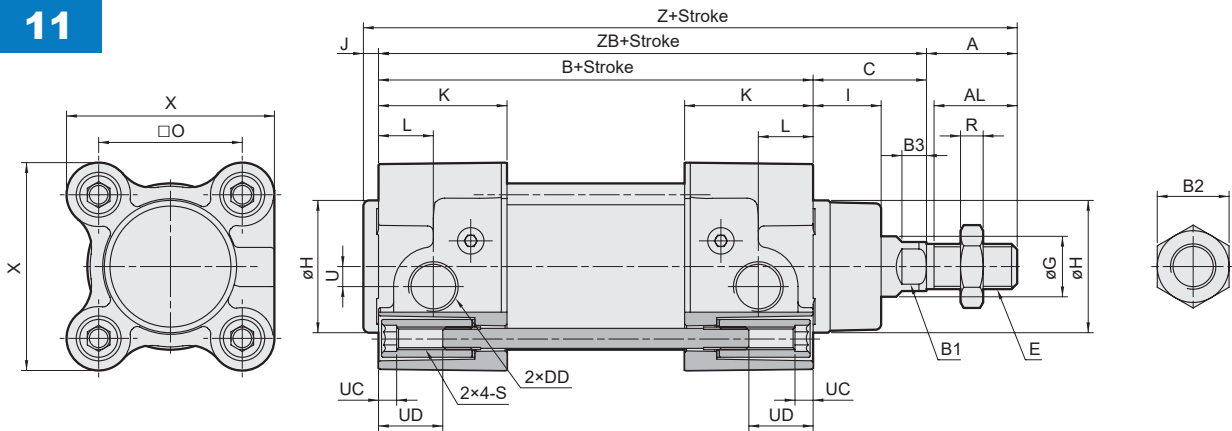

21

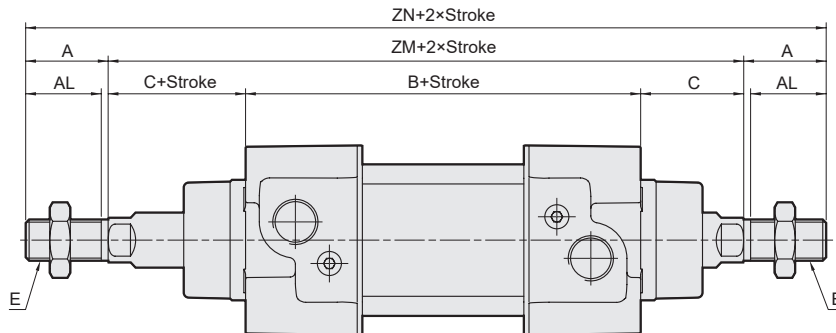

27

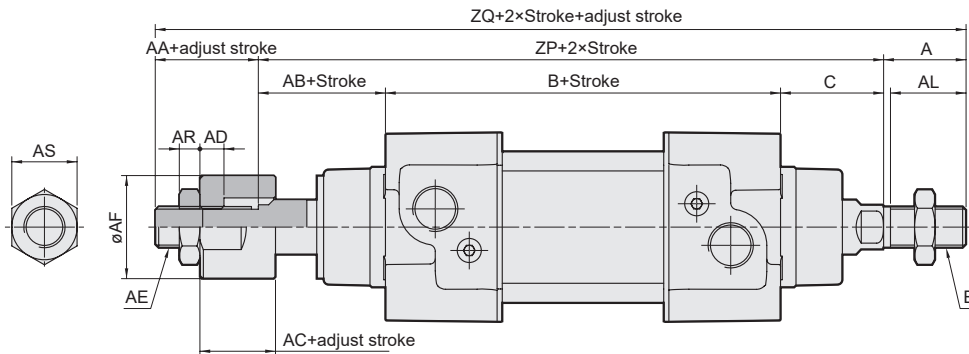

Code Tube I.D.	A	AA	AB	AC	AD	AE	AF	AL	AR	AS	B	B1	B2	B3	C	DD	E	G	H	I	J	K	L	O
32	22	16	26	12	7	M10×1.25	20	20	5	17	94	10	17	4	26	G1/8	M10×1.25	12	30	15	4	30.5	20	32.5
40	24	20	27	12	7	M12×1.25	30	22	6	19	105	13	19	6.5	30	G1/4	M12×1.25	16	35	18	4	34	14.5	38
50	32	18	34	15	10	M16×1.5	40	30	8	24	106	17	24	6	37	G1/4	M16×1.5	20	40	28	4	31	16	46.5
63	32	20	32	15	10	M16×1.5	40	30	8	24	121	17	24	8	37	G3/8	M16×1.5	20	45	26	4	33	17	56.5
80	40	32	41	20	14	M22×1.5	50	38	13	32	128	22	30	10	46	G3/8	M20×1.5	25	45	32.5	4	35.5	20.5	72
100	40	30	46	20	14	M22×1.5	50	38	13	32	138	22	30	10	51	G1/2	M20×1.5	25	55	37.5	4	37	19	89

Code Tube I.D.	R	S	U	UC	UD	X	Z	ZB	ZM	ZN	ZP	ZQ
32	5	M6×1.0	4.5	4.5	16	47	146	120	146	190	146	184
40	6	M6×1.0	5.3	4.5	16	55	163	135	165	213	162	206
50	8	M8×1.25	8.5	4.5	16	65	179	143	180	244	177	227
63	8	M8×1.25	8	4.5	16	78	194	158	195	259	190	242
80	10	M10×1.5	9	4.5	18	95	218	174	220	300	215	287
100	10	M10×1.5	13	4.5	18	115	233	189	240	320	235	305

MCQV3 Installation of sensor switch $\varnothing 32\sim\varnothing 100$

ISO 15552 STANDARD CYLINDER



Mindman

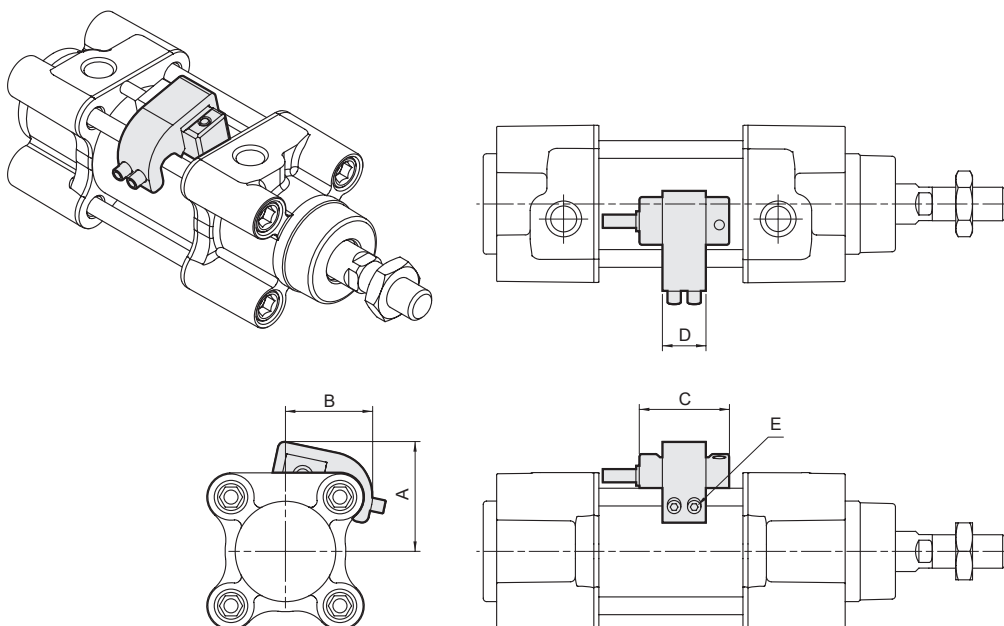

Code Tube I.D.	Sensor switch	Hold	A	B	C	D	E
32	RCA	HV1	34	25	26	13	M4×10L
40	RCA	HV1	34	26	26	13	M4×10L
50	RCA	HV2	43	38	26	13	M4×10L
63	RCA	HV2	48	43	26	13	M4×10L
80	RCA	HV3	55	48	26	13	M5×16L
100	RCA	HV3	62	58	26	13	M5×16L

■ Mounting accessories

LB

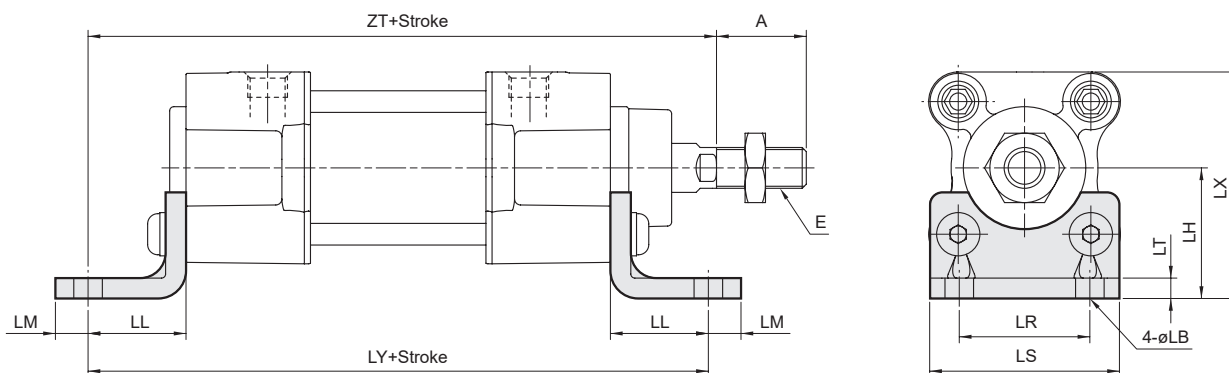

Code Tube I.D.	A	E	LB	LH	LL	LM	LR	LS	LT	LX	LY	ZT
32	22	M10×1.25	7	32	24	8	32	47	5	55.5	142	144
40	24	M12×1.25	9	36	28	10	36	53	5	63.2	161	163
50	32	M16×1.5	9	45	32	10	45	65	5	77.5	170	175
63	32	M16×1.5	9	50	32	10	50	75	5	89.0	185	190
80	40	M20×1.5	12	63	41	13	63	95	6	110.5	210	215
100	40	M20×1.5	14	71	41	13	75	115	6	128.5	220	230

FAC

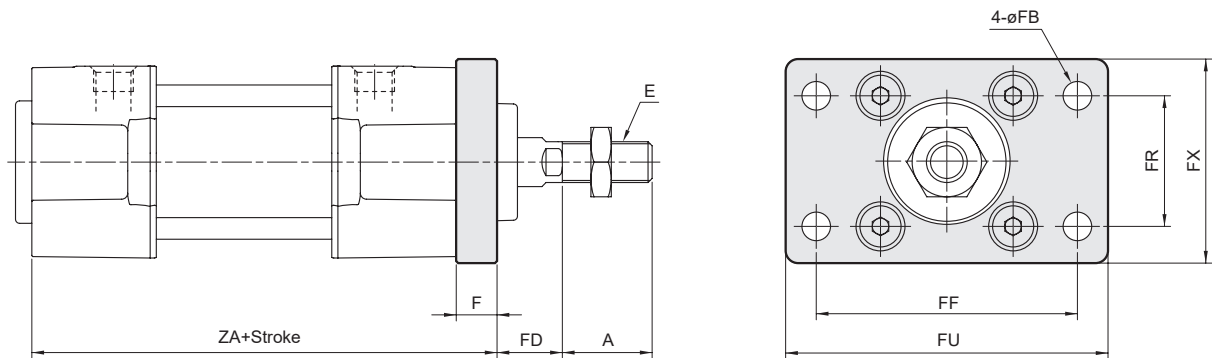

FBC

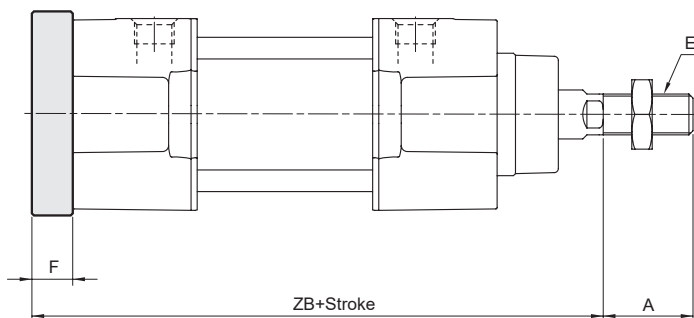

Code Tube I.D.	A	E	F	FB	FD	FF	FR	FU	FX	ZA	ZB
32	22	M10×1.25	10	7	16	64	32	79	50	104	130
40	24	M12×1.25	10	9	20	72	36	90	52	115	145
50	32	M16×1.5	12	9	25	90	45	110	65	118	155
63	32	M16×1.5	12	9	25	100	50	125	76	133	170
80	40	M20×1.5	16	12	30	126	63	154	94	144	190
100	40	M20×1.5	16	14	35	150	75	180	112	154	205

FAC2

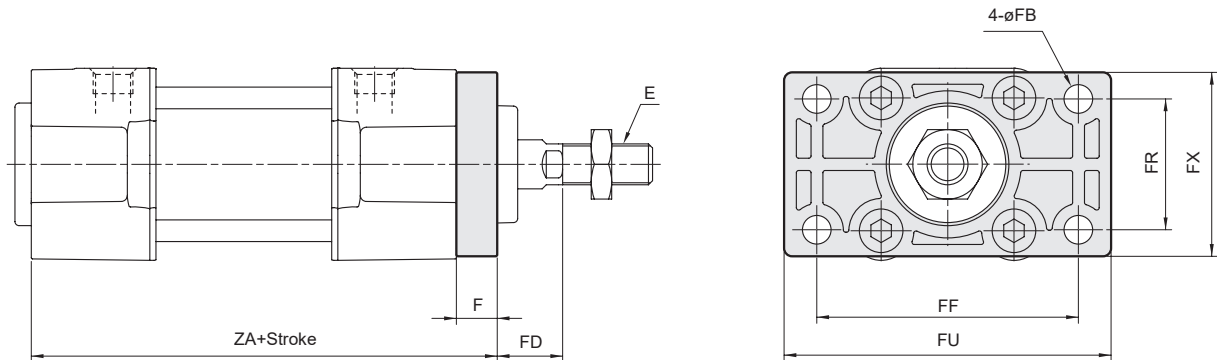

FBC2

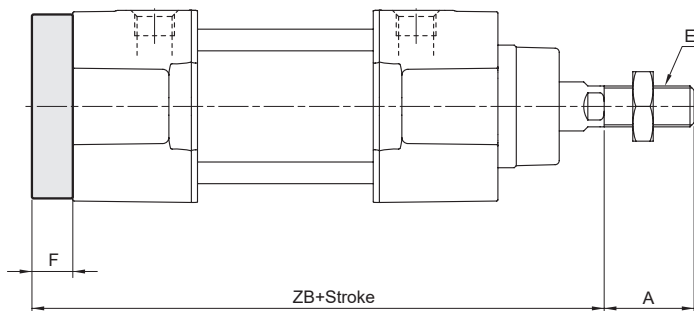

Code Tube I.D.	A	E	F	FB	FD	FF	FR	FU	FX	ZA	ZB
32	22	M10×1.25	10	7	16	64	32	80	45	104	130
40	24	M12×1.25	10	9	20	72	36	90	52	115	145
50	32	M16×1.5	12	9	25	90	45	110	65	118	155
63	32	M16×1.5	12	9	25	100	50	120	75	133	170
80	40	M20×1.5	16	12	30	126	63	150	95	144	190
100	40	M20×1.5	16	14	35	150	75	175	115	154	205

CA

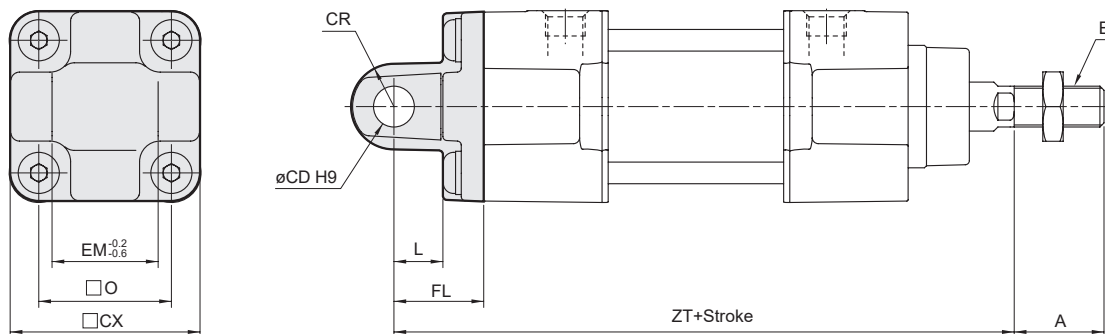

CB

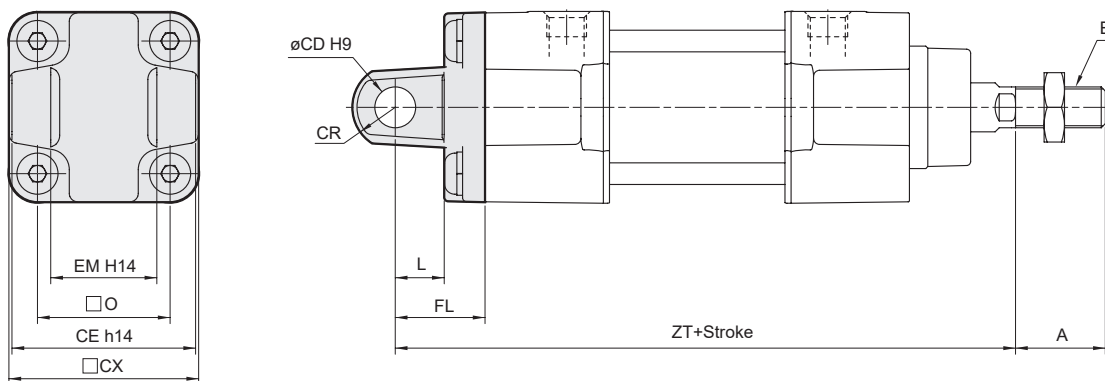

CDB

CB+Pin (Extra purchase)

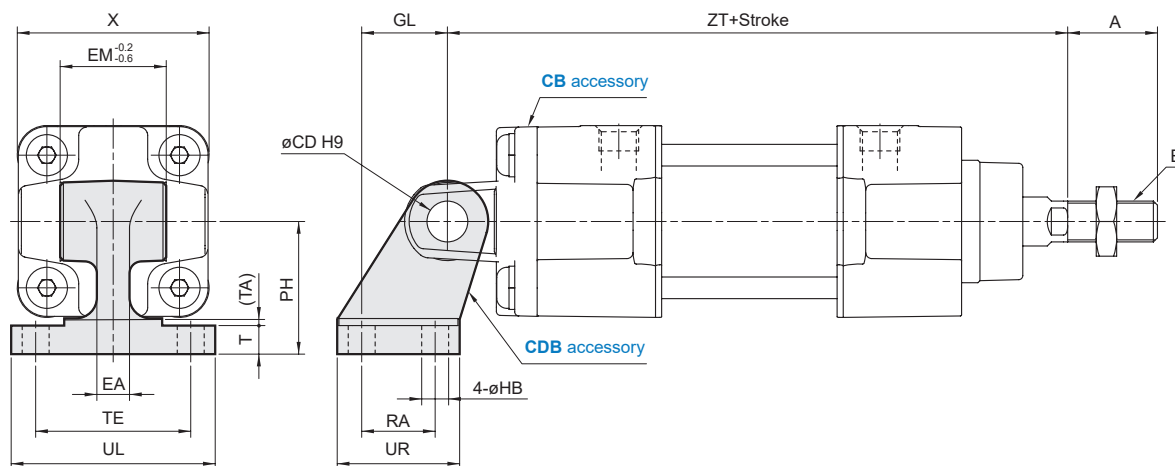

Code Tube I.D.	A	CD	CE	CR	CX	E	EA	EM	FL	GL	HB	L	O	PH	RA	T	TA	TE	UL	UR	X	ZT
32	22	10	45	R10.5	46.5	M10×1.25	8	26	22	21	6.6	12	32.5	32	18	6.5	1.5	38	50	30	47	142
40	24	12	52	R12	54	M12×1.25	10	28	25	24	6.6	15	38	36	22	8.5	1.5	41	53	34	55	160
50	32	12	60	R13	64	M16×1.5	10	32	27	33	9	15	46.5	45	30	10.5	1.5	50	65	45	65	170
63	32	16	70	R17	75	M16×1.5	12	40	32	37	9	20	56.5	50	35	10.5	1.5	52	67	50	78	190
80	40	16	90	R17	93	M20×1.5	12	50	36	47	11	20	72	63	40	11.5	2.5	66	86	60	95	210
100	40	20	110	R21	114	M20×1.5	16	60	41	55	11	25	89	71	50	12.5	2.5	76	96	70	115	230

CA2

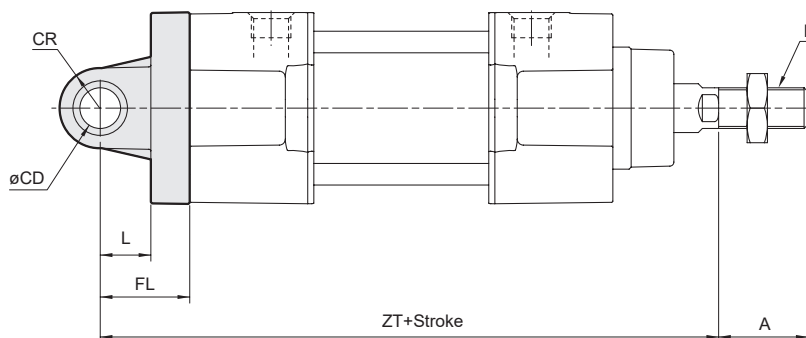
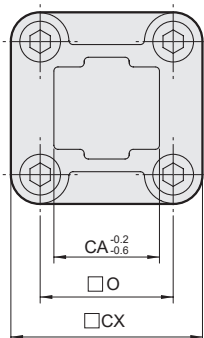

CB2

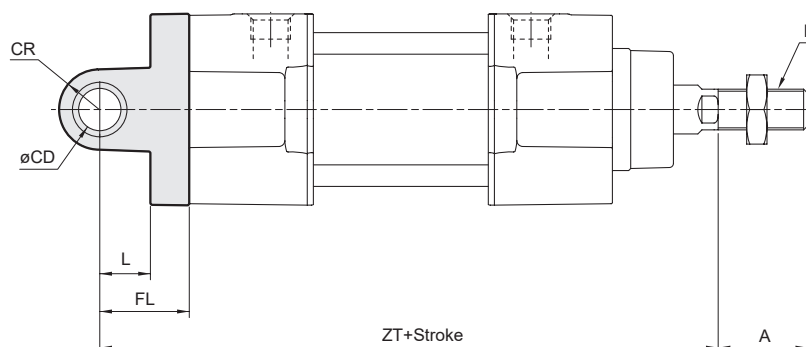
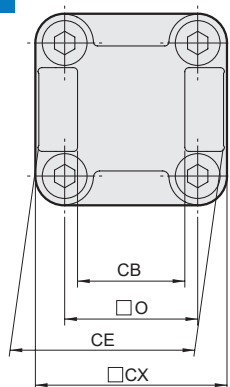

CDB2

CB2+Pin (Extra purchase)

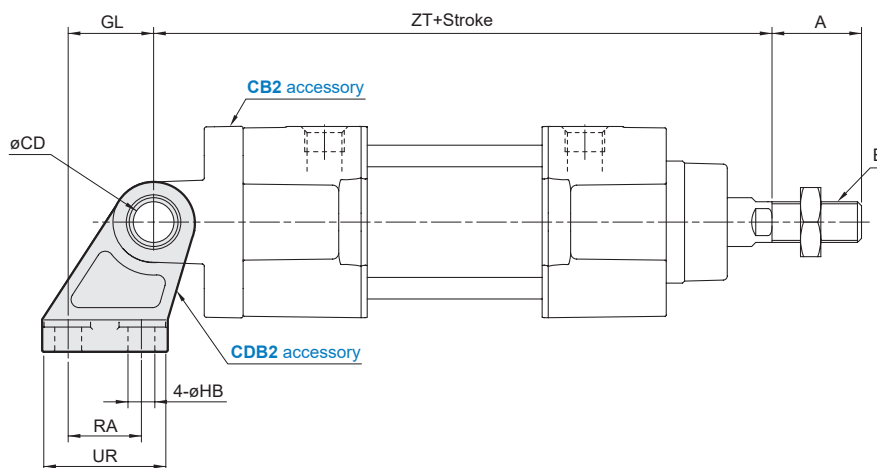
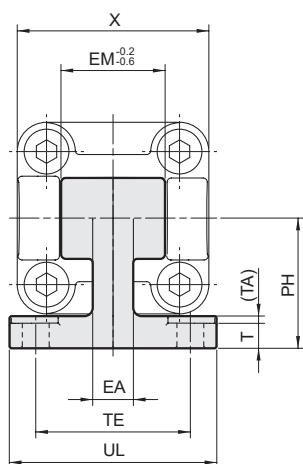

Code Tube I.D.	A	CA	CB ^{H14}	CD ^{H9}	CE ^{H14}	CR	CX	E	EA	EM	FL	GL	HB	L	O	PH	RA	T	TA	TE	UL	UR	X	ZT
32	22	26	26 ^{+0.052} / ₀	10 ^{+0.036} / ₀	45 ⁰ / _{-0.62}	R10	47	M10×1.25	10	26	22	21	6.6	12.5	32.5	32	18	8	1.6	38	51	31	47	142
40	24	28	28 ^{+0.052} / ₀	12 ^{+0.043} / ₀	52 ⁰ / _{-0.74}	R12	53	M12×1.25	15	28	25	24	6.6	16	38	36	22	10	1.6	41	54	35	55	160
50	32	32	32 ^{+0.062} / ₀	12 ^{+0.043} / ₀	60 ⁰ / _{-0.74}	R12	65	M16×1.5	16	32	27	33	9	16	46.5	45	30	12	1.6	50	65	45	65	170
63	32	40	40 ^{+0.062} / ₀	16 ^{+0.043} / ₀	70 ⁰ / _{-0.74}	R16	75	M16×1.5	16	40	32	37	9	21	56.5	50	35	14	1.6	52	67	50	78	190
80	40	50	50 ^{+0.062} / ₀	16 ^{+0.043} / ₀	90 ⁰ / _{-0.87}	R16	95	M20×1.5	20	50	36	47	11	22	72	63	40	14	2.5	66	86	60	95	210
100	40	60	60 ^{+0.074} / ₀	20 ^{+0.052} / ₀	110 ⁰ / _{-0.87}	R20	115	M20×1.5	20	60	41	55	11	27	89	71	50	17	2.5	76	96	70	115	230

TC

SDS

Mid section support
Stroke over 1000mm

For SDS accessories,
the area do not exist.

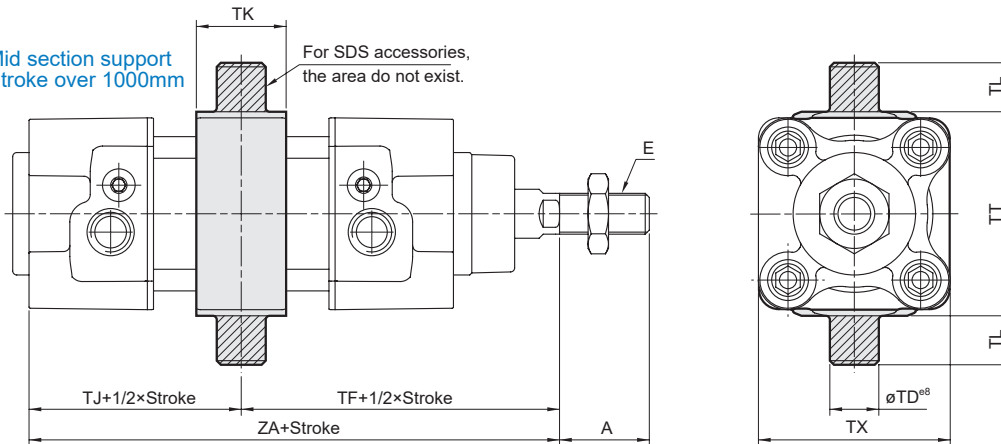

TA

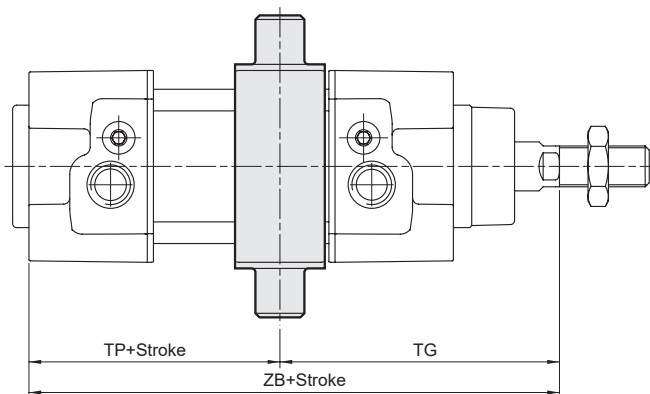

TB

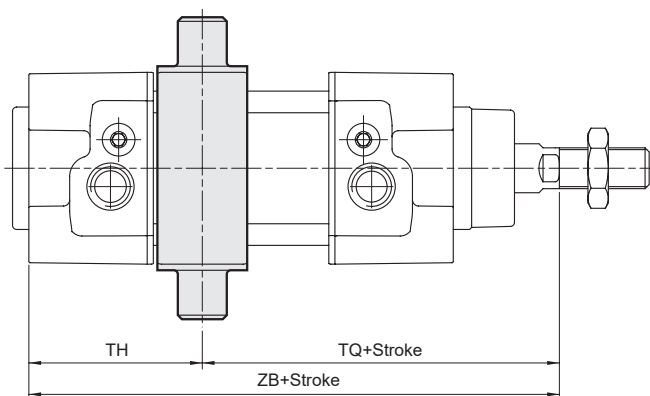

Code Tube I.D.	A	E	TD	TF	TG	TH	TJ	TK	TL	Without magnet			Magnet			TC	SDS	TX	ZA
										TP	TQ	ZB	TP	TQ	ZB				
32	22	M10×1.25	12	73	68.5	42.5	47	22	12	51.5	77.5	120	81.5	107.5	150	50	49	47	120
40	24	M12×1.25	16	82.5	76	46	52.5	22	16	59	89	135	89	119	165	63	55	53	135
50	32	M16×1.5	16	90	80	43	53	22	16	63	100	143	93	130	173	75	68	66	143
63	32	M16×1.5	20	97.5	85	48	60.5	28	20	73	110	158	103	140	188	90	82	80	158
80	40	M20×1.5	20	110	99.5	53.5	64	34	20	74.5	120.5	174	114.5	160.5	214	110	108	106	174
100	40	M20×1.5	25	120	109	58	69	40	25	80	131	189	120	171	229	132	130	126	189

Y connector

$\phi 32 \sim \phi 40$

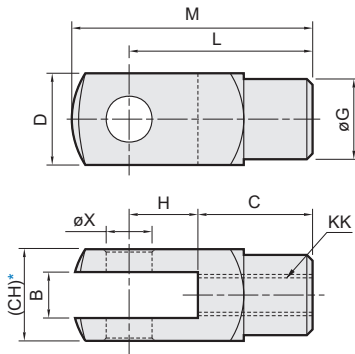

$\phi 50 \sim \phi 100$

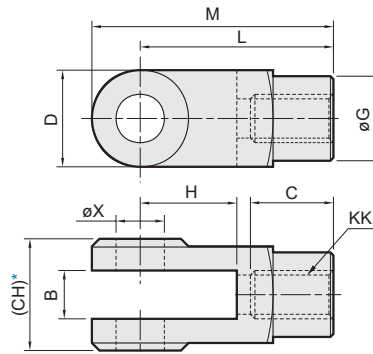

I connector

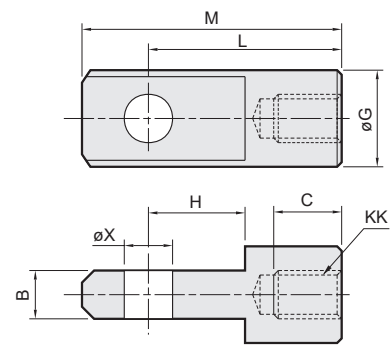

* Please do not take the sand casting plate as the mounting plate, because we do not machine it.
If you have this special demand, please contact our sales representative.

Code Tube I.D.	B		C		CH		D		G		H		KK		L		M		X ^{H9}
	Y	I	Y	I	Y	I	Y	I	Y	I	Y	I	Y	I	Y	I	Y	I	
32	10 ^{+0.5 +0.15}	10 ^{-0.1 -0.2}	20	17	19	—	19	—	ø18	ø20	20	15	M10×1.25	40	40	52	52	ø10 ^{+0.04 0}	
40	12 ^{+0.5 +0.15}	12 ^{-0.1 -0.2}	24	21	22	—	22	—	ø20	ø24	24	18	M12×1.25	48	48	62	62	ø12 ^{+0.04 0}	
50	16 ^{+0.3 +0.1}	16 ^{-0.1 -0.3}	28	23	32	—	32	—	ø28	ø32	32	32	M16×1.5	64	64	89	86	ø16 ^{+0.04 0}	
63	16 ^{+0.3 +0.1}	16 ^{-0.1 -0.3}	28	23	32	—	32	—	ø28	ø32	32	32	M16×1.5	64	64	89	86	ø16 ^{+0.04 0}	
80	20 ^{+0.3 +0.1}	20 ^{-0.1 -0.3}	33	30	45	—	40	—	ø36	ø36	40	40	M20×1.5	80	80	100	108	ø20 ^{+0.05 0}	
100	20 ^{+0.3 +0.1}	20 ^{-0.1 -0.3}	33	30	45	—	40	—	ø36	ø36	40	40	M20×1.5	80	80	100	108	ø20 ^{+0.05 0}	

PIN

S

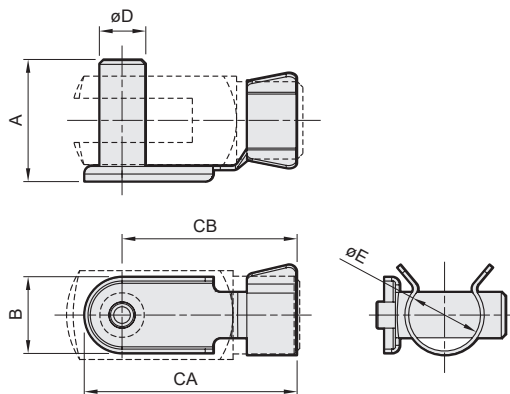

for floating pin

Code Tube I.D.	A	B	CA	CB	D ^{d9}	E
32	26	14	45	38	ø10 ^{-0.04 -0.07}	17
40	31	16	54	46	ø12 ^{-0.05 -0.09}	19
50,63	42	20	70	60	ø16 ^{-0.05 -0.09}	27
80,100	56	30	91	76	ø20 ^{-0.06 -0.11}	35

P

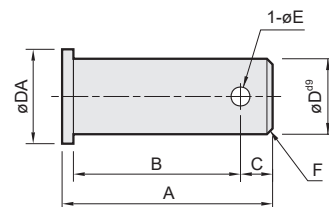

for Y & I connector

Code Tube I.D.	A	B	C	D ^{d9}	DA	E	F	Split pin
32	30	25	3.5	ø10 ^{-0.06 -0.09}	14	3.2	1	3.2×20L
40	37	30	5	ø12 ^{-0.06 -0.09}	16	3.2	1	3.2×20L
50,63	47	37	7	ø16 ^{-0.05 -0.09}	22	4	1	4×25L
80,100	62	50	8	ø20 ^{-0.06 -0.11}	30	5	1.5	5×35L

P

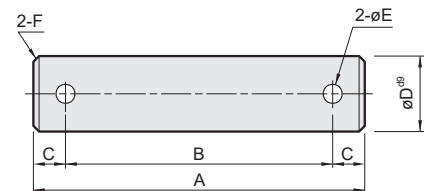

for CA & CB

Code Tube I.D.	A	B	C	D ^{d9}	E	F	Split pin
32	69	55	7	ø10 ^{-0.05 -0.09}	4	1.0	4×20L
40	76	62	7	ø12 ^{-0.05 -0.09}	4	1.0	4×20L
50	84	70	7	ø12 ^{-0.05 -0.09}	4	1.0	4×20L
63	94	80	7	ø16 ^{-0.05 -0.09}	4	1.0	4×30L
80	117	100	8.5	ø16 ^{-0.05 -0.09}	5	1.5	5×30L
100	137	120	8.5	ø20 ^{-0.05 -0.09}	5	1.5	5×35L

MCQV3 Solenoid valve link seats $\phi 40, \phi 50$



ISO 15552 **STANDARD CYLINDER**

mindman

Order example

MCQV3 — As standard order example — VR — 4E2C — 6A — AC110 — L

MODEL

SOLENOID VALVE
LINK SEATS

VR: Installed on the front cover
VH: Installed on the back cover

4 way (5 port)

E1: Single solenoid
E2: Double solenoid

C: Closed center
P: Pressure center
R: Exhaust center
(Only for
MVSN-300-4E2)

PORT
SIZE

6A: G1/8
(Only for
MVSN-220)
8A: G1/4

VOLTAGE

AC220V(50/60)Hz
AC110V(50/60)Hz
DC24V

ELECTRIC CONNECTION

Standard	
Blank	DIN terminal
L	DIN terminal with LED indicator
E	Explosion protection
Power saving (for DC24V)	
KL	DIN terminal with LED indicator

* MCQV3- $\phi 40$ (for MVSN-220 valve, please refer to page 1-66 (Vol.1).)

* MCQV3- $\phi 50$ (for MVSN-220 valve, please refer to page 1-68 (Vol.1).)

MVSN-300-C Solenoid valve link seats

Solenoid valve link seats

Mounting of solenoid valve link seats

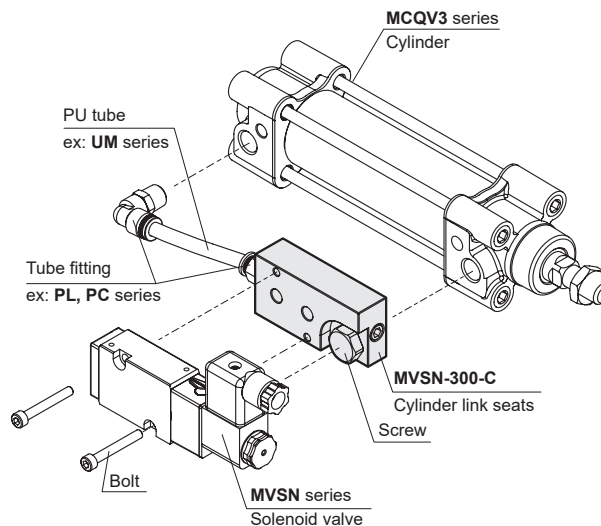
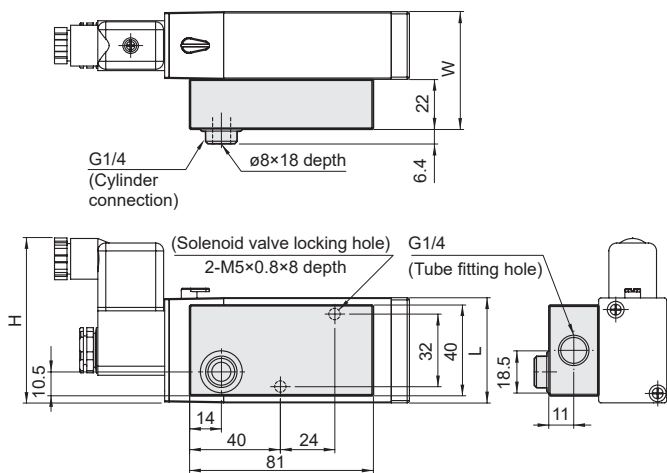

Code Model	H	W	L	Cylinder type
MVSN-220	70	44.3	40	MCQV3/MCQI3 $\phi 40$
MVSN-300	73	52	46.4	MCQV3/MCQI3 $\phi 50$