

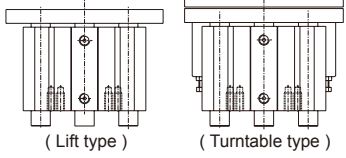

### Features

- Three guide rods equally spaced enable consistent movement even when uneven load is applied.
- Increases productivity on conveyor lines.
- When connected to a rotary actuator the unit can be used as an auto turn lifter.
- Magnetic as standard.

### Specification

Model	MCG3	
Model (Stop type view)		
Acting type	Double acting	
Tube I.D.(mm)	63	80
Port size	Rc1/4	Rc3/8
Standard stroke	30, 50, 75, 100 mm	
Medium	Air	
Operating pressure range	0.1~1 MPa	
Proof pressure	1.5 MPa	
Ambient temperature	-5~+60°C (No freezing)	
Cushion	With rubber cushion pad	
Available speed range	50~500 mm/sec	
Lubrication	Not required	
Sensor switch (*)	RCB, RCE, RCE1, RDEP	

\* RCB, RCE, RCE1, RDEP specification, please refer to page 8-8, 10, 14.

### Order example

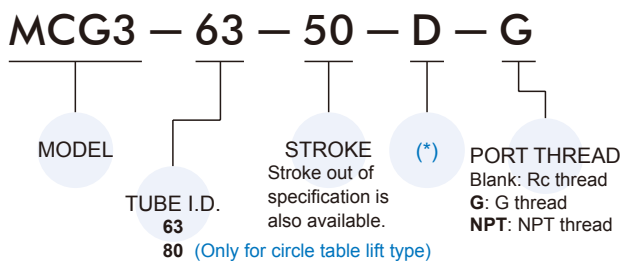

### \* APPLICATION / TYPE OF BEARING

Code	Purpose / Type of bearing
D	Circle table lift / Slide bush
B	Circle table lift / Linear bearing
D90	Turntable / Angle 90° / Slide bush
B90	Turntable / Angle 90° / Linear bearing
D180	Turntable / Angle 180° / Slide bush
B180	Turntable / Angle 180° / Linear bearing
QD	Quad table lift / Slide bush
QB	Quad table lift / Linear bearing

### Allowable eccentric load

(at supply pressure 0.5MPa)

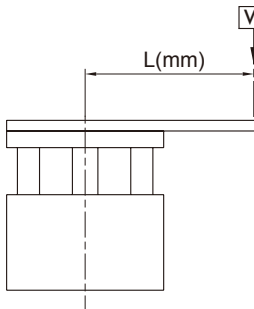

Shows the dynamic allowable value at L(mm) eccentricity from the center of the guide rod.

MCG3-D/D90/D180

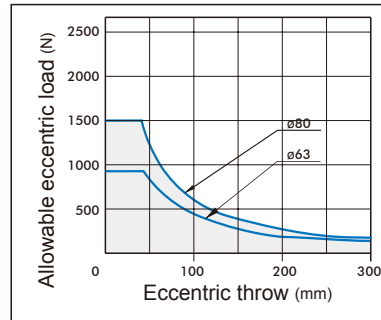

MCG3-B/B90/B180

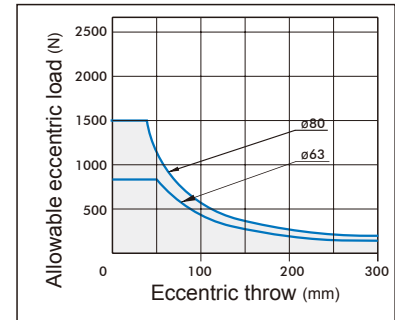

### Allowable rotating torque

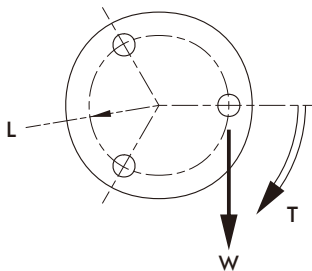

Shows the dynamic allowable value, when actuating the cylinder with a rotating torque T at the guide rods' top.

Unit: N.m

Tube I.D.	Bearing type	Stroke (mm)		
		30	50	100
ø63	Slide bush	13.2	12.7	7.6
	Linear bearing	13.5	12.7	8.8

### Anti-roll accuracy

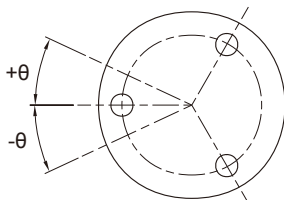

The values are the deflection angle against the piston rod.

Tube I.D.	Bearing type	Anti-roll accuracy
		$\theta$
ø63	Slide bush	$\pm 0.07^\circ$
	Linear bearing	$\pm 0.03^\circ$

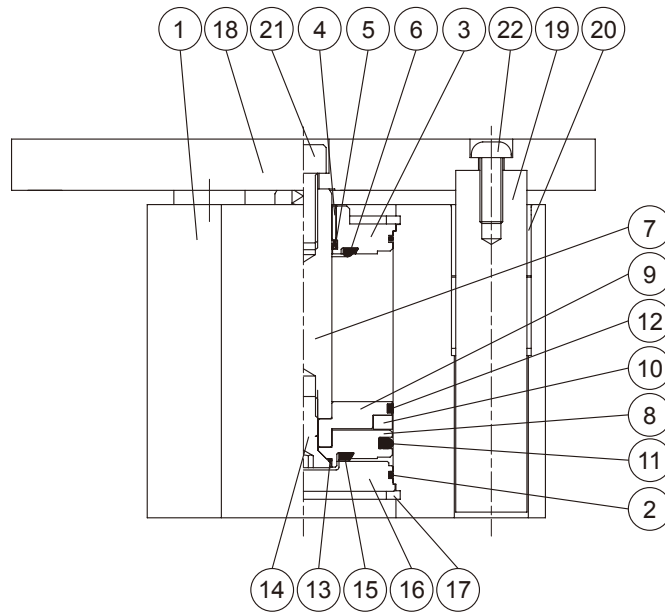

### Material

No.	Part name	Material	Q'y	Repair kits (inclusion)
1	Body	Aluminum alloy	1	
2	Cover ring	NBR	2	●
3	Rod cover	Aluminum alloy	1	
4	Rod bush	Bearing alloy	1	
5	Rod packing	NBR	1	●
6	Rod cushion	NBR	1	●
7	Piston rod	Carbon steel	1	
8	Piston	Aluminum alloy	1	
9	Piston for magnet ring	Aluminum alloy	1	
10	Magnet ring	Magnet material	1	
11	Piston packing	NBR	1	●
12	Wear ring	Teflon	1	
13	Piston gasket	NBR	1	●
14	Bolt for piston	Carbon steel	1	
15	Head cushion	NBR	1	●
16	End cover	Aluminum alloy	1	
17	Snap ring	Spring steel	2	
18	Plate	Carbon steel	1	
19	Guide rod	Carbon steel	3	
20	Guide rod bush	Bearing alloy	6	
21	Bolt for piston rod	Carbon steel	1	
22	Bolt for guide rod	Carbon steel	3	

### Order example of repair kits

Tube I.D.	Repair kits
ø63	<b>PS-MCG3-63</b>
ø80	<b>PS-MCG3-80</b>

### MCG3-D/B

(Lift type)

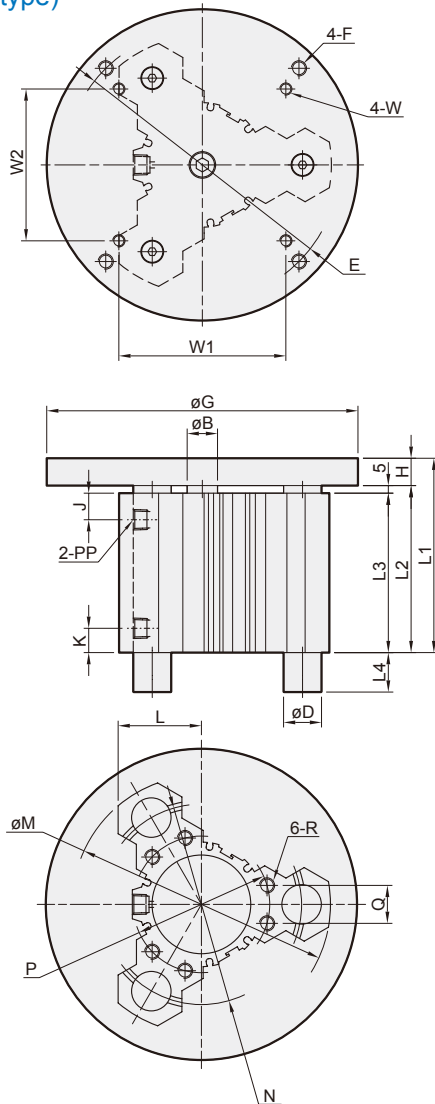

### MCG3-D90/B90/D180/B180 for ø63

(Turntable type)

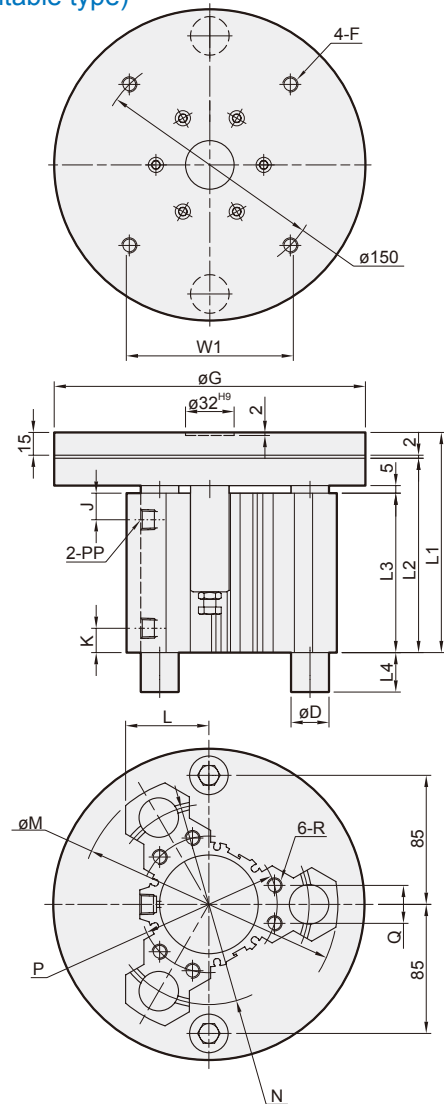

### MCG3-D/B

Code Tube I.D.	B	E	F	G	H	J	K	L	M	N	P	PP	Q	R	W	W1	W2
63	20	P.C.D180	M10×1.5	205	18	17.5	16	54.8	170	P.C.D132	P.C.D90	Rc1/4	25	M10×1.5×23depth	M8×1.25	110	100
80	25	P.C.D190	M10×1.5	220	18	22	22	61.2	190	P.C.D150	P.C.D106	Rc3/8	32	M10×1.5×23depth	—	—	—

Tube I.D.	L1				L2				L3			
	Stroke (mm)											
	30	50	75	100	30	50	75	100	30	50	75	100
63	108	128	153	178	90	110	135	160	85	105	130	155
80	118	138	163	188	100	120	145	170	95	115	140	165

Tube I.D.	L4		øD	
	MCG3-D	MCG3-B	MCG3-D	MCG3-B
63	0	26	ø25	ø16
80	0	25	ø28	ø20

### MCG3-D90/B90/D180/B180

Tube I.D.	L1				L2				L3			
	Stroke (mm)											
	30	50	100	30	50	100	30	50	100			
63	125	145	195	108	128	178	85	105	155			

Tube I.D.	L4		øD	
	D90 / D180	B90 / B180	D90 / D180	B90 / B180
63	0	26	ø25	ø16

### MCG3-QD/QB

(Lift type)

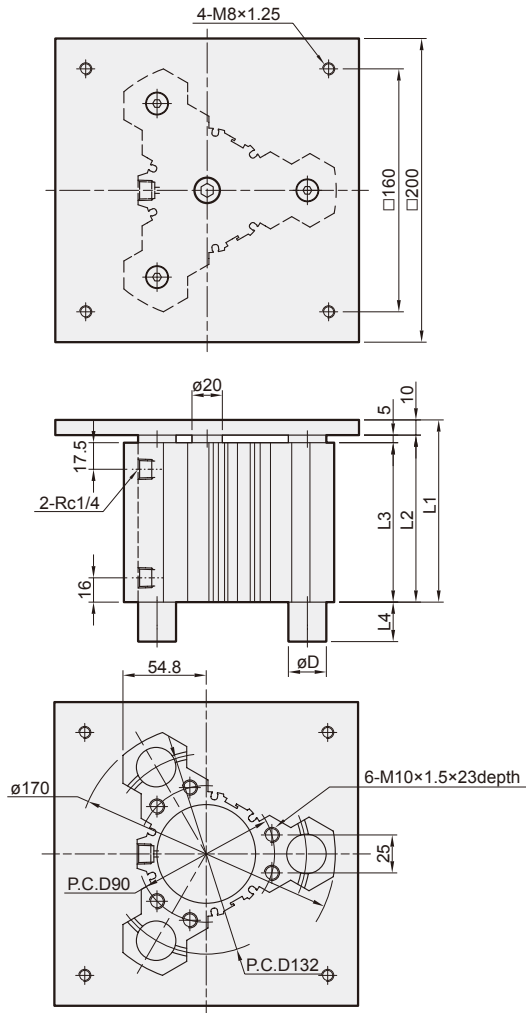

### Installation of sensor switch

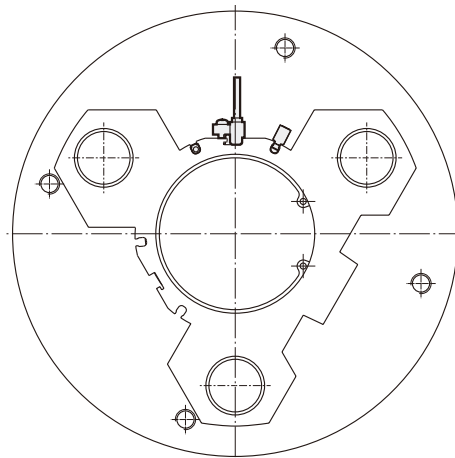
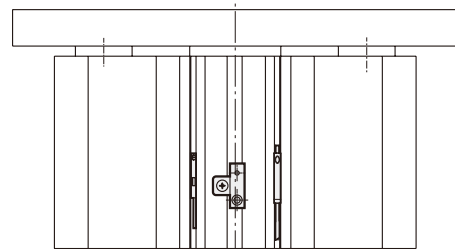
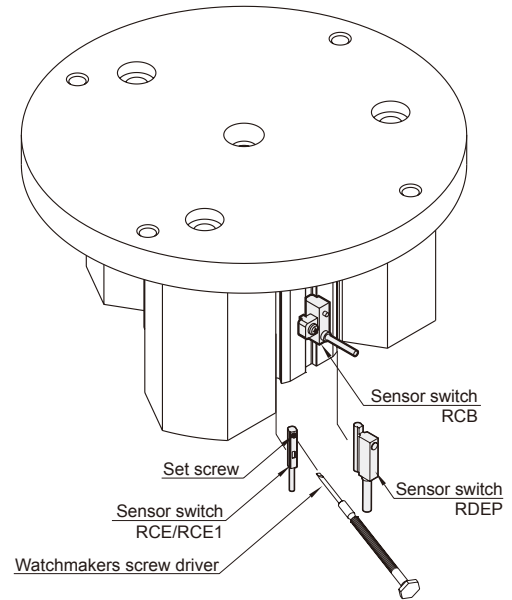

### MCG3-QD/QB

Tube I.D.	Stroke (mm)	L1	L2	L3
63	30	100	90	85
	50	120	110	105
	75	145	135	130
	100	170	160	155

Tube I.D.	L4		$\phi D$	
	MCG3-QD	MCG3-QB	MCG3-QD	MCG3-QB
63	0	26	$\phi 25$	$\phi 16$