

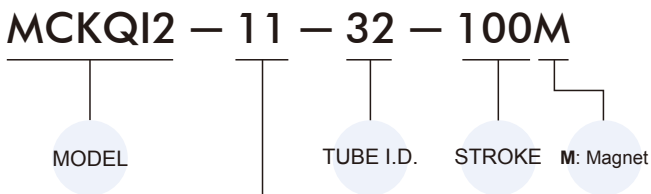

Table for standard stroke

Tube I.D.	Stroke (mm)
ø32,40	50,75,100,125,150,175,200,250,300

- Stroke out of specification is also available.
- Please consult us if stroke out of specification.

Order example





STYLE

Code	Symbol	Description
1 1		Double acting / Male thread

- * Order example for special specification, refer to page 0-7.
- * Order example for Rc or NPT thread please consult us.

Cylinder weight

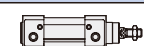
Unit: kg

Model	Basic weight	Basic weight (magnet)	Stroke 25 mm
Tube I.D.			
ø32	0.550	0.556	0.067
ø40	0.823	0.829	0.086

Features

■ Hexagonal rod design & Non lubrication

Cylinder with hexagonal rod design enables non-rotation of rod. Special housing and bushing enables self lubrication of piston rod.

■ High quality long service life

Hard anodised aluminium cylinder tubes offer a high resistance to corrosion and low internal friction.

■ ISO-VDMA standard specification

Conforms to ISO-6431 and VDMA 24562 specification enabling worldwide interchangeability.

■ Easy to insert reed switch

With four grooves on the tube, proximity and reed sensors can be easily inserted into any position.

Specification









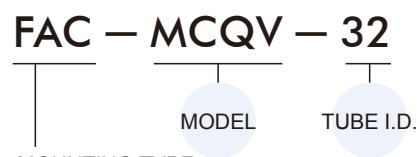

Model	MCKQI2	
Tube I.D. (mm)	32	40
Medium	Air	
Operating pressure range	0.05~1 MPa	
Proof pressure	1.5 MPa	
Ambient temperature	-5~+60°C (No freezing)	
Available speed range	50~500 mm/sec	
Rod non-rotating accuracy	±0.5°	
Allowable rotational torque	2.5 kgf-cm	4.5 kgf-cm
Sensor switch (*)	RCI	

* RCI specification, please refer to page 8-11.

Mounting accessories

* Use the same accessories with MCQV.

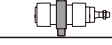
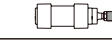
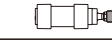

	LB
	CA
	CB
	CDB (+CB+PIN)*
	FAC
	FBC
	TA
	TB
	TC
	Y
	I
	YS (Y+Floating+PIN)

* CB+PIN have to extra purchase.

Model is MCKQI2

Refer to MCQV dimension

MCKQI2 Inside structure & Parts list / Dimensions



ISO-VDMA STANDARD WITH NO-ROTATION PROFILE CYLINDER

mindman

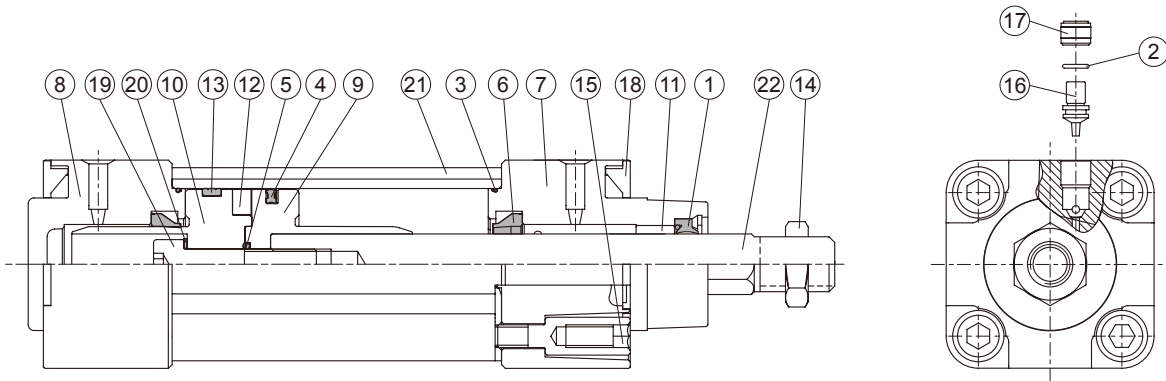

Material

No.	Part name	Material	Q'y	Component parts (inclusion)	Repair kits (inclusion)
1	Rod packing	NBR	1	●	●
2	O-ring	NBR	2	●	
3	O-ring	NBR	2	●	●
4	Piston packing	NBR	1	●	●
5	O-ring	NBR	1	●	●
6	Cushion packing	NBR	2	●	●
7	Rod cover	Aluminum alloy	1	●	
8	Head cover	Aluminum alloy	1	●	
9	Piston-R	Aluminum alloy	1	●	
10	Piston-H	Aluminum alloy	1	●	
11	Bush	Bearing alloy	1	●	
12	Magnet ring	Magnet material	1	●	
13	Wear ring	Teflon	1	●	
14	Nut	Carbon steel	1	●	
15	Screw	Carbon steel	8	●	
16	Needle valve	Copper alloy	2	●	
17	Insert nut	Copper alloy	2	●	
18	Cover plate	Plastic	2	●	
19	Bolt	Carbon steel	1	●	
20	Washer	Carbon steel	1	●	
21	Cylinder tube	Aluminum alloy	1		
22	Piston rod	Stainless steel	1		
23	Snap ring	Spring steel	1	●	
24	Washer	Carbon steel	1	●	

Order example of component parts

CP – MCKQI2 – □ – 40 M

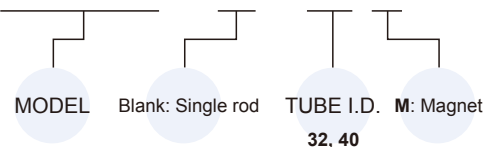

* Order example for Rc or NPT thread please consult us.

Order example of repair kits

PS – MCKQI2 – □ – 40

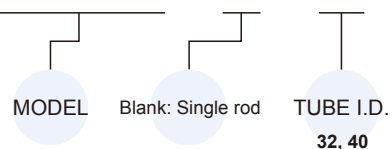

Dimensions

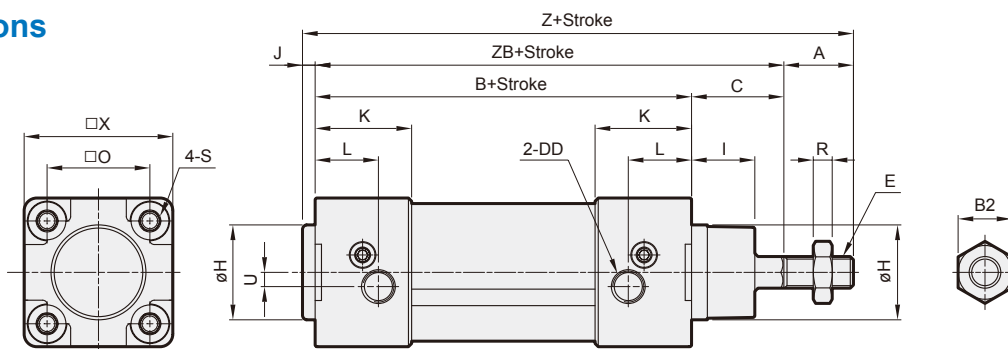

Code Tube I.D.	A	B	B2	C	DD	E	H	I	J	K	L	O	R	S	U	X	Z	ZB
32	22	94	17	26	G1/8	M10×1.25	30	20	4	30.5	20	32.5	5	M6×1.0	4.5	47	146	120
40	24	105	19	30	G1/4	M12×1.25	35	20.5	4	34	14.5	38	6	M6×1.0	5.3	55	163	135